



**Is performance
the reason to drive
the new Citroën DS-21?**

It's only one!

1966 Citroën Techn

	DS-21	DS-19	ID-19
Displacement—cc	2175 cc	1985 cc	1911 cc
Displacement—cu. in.	132.7 cu. in.	121.1 cu. in.	116.6 cu. in.
Compression Ratio	8.75 to 1	8.5 to 1	8 to 1
SAE Power @ rpm	109 bhp @ 5500	90 bhp @ 5250	81 bhp @ 4750
Max. Torque S.A.E.	128 ft. lbs. @ 3000-3500 rpm	110 ft. lbs @ 3500 rpm	104 ft. lbs. @ 3500 rpm
Central Spark Plug Location	Yes	Yes	Yes
Bore	3.543 in. 90 mm	3.386 in. 86 mm	2.992 in. 78 mm
Stroke	3.366 in. 85.5 mm	3.366 in. 85 mm	3.937 in. 100 mm
Combustion Chamber	Hemispherical	Hemispherical	Hemispherical
Cylinder Head	Aluminum alloy	Aluminum alloy	Aluminum alloy
Intake Manifold	External	Integral	Integral
Oil Filter	Internal with bi-pass, plus screen in sump	Internal with bi-pass, plus screen in sump	Screen in sump
Radiator	Copper core 60 mm	Steel core 40 mm	Steel core 40 mm
Cooling System	Water pump & thermostat	Water pump & thermostat	Water pump & thermostat
Fan	8 Blade nylon	8 Blade nylon	8 Blade nylon
Fuel Pump	Mechanical	Mechanical	Mechanical
Generator	400 watts with voltage regulator	400 watts with voltage regulator	300 watts with voltage regulator
Battery	12 Volt-55 AH	12 Volt-55AH	12 Volt-55AH
Valve Arrangement	60°-OHV	60°-OHV	60°-OHV
Carburetor	Double barrel Weber DDEA2-28 x 36	Double barrel Weber DDE2—28 x 36	Solex downdraft
Exhaust	Dual system with rear expansion chamber	Single	Single
Cam Shaft	4 bearings, high lateral position chain drive	High lateral position chain drive	3 bearings, lateral position chain drive
Pistons	Recessed dome	Recessed dome	Domed
Connecting Rods	Positive centered cap	Positive centered cap	
Crankshaft: Main Bearings	5	5	3
Clutch	Single Plate Dry Type	Single Plate Dry Type	Single Plate Dry Type
Gear Box	4 speed fully synchromeshed with manual shift or New Quick-Action CITROMATIC-DRIVE	4 speed fully synchromeshed with manual shift or New Quick-Action CITROMATIC-DRIVE	4 speed full synchromesh
Citromatic-Drive	Automatic hydraulic Quick-Action control with centrifugal governor and new throttle regulator	Automatic hydraulic Quick-Action control with centrifugal governor and new throttle regulator	Not available
Final Drive	Spiral Bevel—8 x 35 4.375 to 1	Spiral Bevel—8 x 35 4.375 to 1	Spiral Bevel—8 x 31 3.87 to 1
Gear Ratios	1st —14.21 to 1 2nd — 8.49 to 1 3rd — 5.58 to 1 4th — 3.73 to 1 R—13.80 to 1	1st —14.21 to 1 2nd— 8.49 to 1 3rd — 5.58 to 1 4th — 3.73 to 1 R—13.80 to 1	1st —13.79 to 1 2nd— 7.45 to 1 3rd — 4.77 to 1 4th — 3.31 to 1 R—14.82 to 1
Drive Shaft	Double homokinetic constant velocity tripod universals	Double homokinetic constant velocity tripod universals	Double homokinetic constant velocity tripod universals
Front Wheel Drive	Indeed!	Naturally!	Of Course!
Brakes: Power assisted Dual Independent System with Proportional action.	Front: Inboard Disc with two opposed pistons caliper. Rear: Drum	Front: Inboard Disc with two opposed pistons caliper. Rear: Drum	Front: Inboard Disc with two parallel pistons caliper Rear: Drum
Emergency Brakes: Mechanical on front disc	Autonomous system with separate pads	Autonomous system with separate pads	On primary system
Brake pressure warning	Light on dash	Light on dash	Light on dash
Brake Pad Wear Warning	Light on dash	N. A.	N. A.
Brake Cooling	Large underpan ducts	Large underpan ducts	Large underpan ducts
Steering System	Rack & Pinion, 3¼ turns lock-to-lock. Power assist standard	Rack & Pinion, 3¼ turns lock-to-lock. Power assist standard	Rack & Pinion, 4 turns lock-to-lock. ¾ turns with optional power assist
Wheels	Steel—15"	Steel—15"	Steel—15"
Tires: New All-Weather Michelin "X AS" Radial Steel Cord with Asymmetrical Construction and Tread Design.	Mandatory 180 x 380 size Front pressure: 27 lbs. Rear pressure: 24 lbs.	Mandatory 180 x 380 size Front pressure: 27 lbs. Rear pressure: 24 lbs.	Mandatory 180 x 380 size Front pressure: 27 lbs. Rear pressure: 24 lbs.
Suspension System	Hydropneumatic	Hydropneumatic	Hydropneumatic
Variable Ground Clearance	Yes	Yes	Yes
Power Jacking	Yes	Yes	Yes
Constant Level Ride	Yes	Yes	Yes

Technical Specifications

	DS-21	DS-19	ID-19
Integral Hydropneumatic Shock Absorbers	Special High Speed	Special High Speed	Standard type
1 Piece Body Frame All Steel Construction	Yes	Yes	Yes
Factory Rust Proofing	Prepaint by electrophoresis	Prepaint by electrophoresis	Prepaint by electrophoresis
Underpan	Full length	Full length	Full length
Headlights	Sealed beam with automatic dynamic adjustment	Sealed beam	Sealed beam
Horns	Custom triple	Deluxe Dual	Single
Weight	2855 lbs. sedan—2900 conv.	2855 lbs.	2668 lbs.
Loaded Weight	3880 lbs. sedan	3880 lbs.	3698 lbs.
Safety Glass As-1 As-2	Yes	Yes	Yes
Tinted Windshield	Optional	Optional	Optional
Wheelbase	123"	123"	123"
Overall Length	190.5"	190.5"	190.5"
Overall Width	70.5"	70.5"	70.5"
Trunk Capacity	17.5 cu. ft.	17.5 cu. ft.	17.5 cu. ft.
Fuel Tank Capacity	17 gallons	17 gallons	17 gallons
Crank Case Capacity	4 quarts	4 quarts	4 quarts
Gear Box Capacity	2 quarts	2 quarts	2 quarts
Radiator Capacity	11 qts. Single Heater 15 qts. Dual	11 qts. Single Heater 15 qts. Dual	11 qts. Single Heater 15 qts. Dual
Performance			
0- 60 miles per hour	12.5 seconds	NA	NA
0- 80 miles per hour	24 seconds	NA	NA
0-100 miles per hour	63 seconds	NA	NA
Top Speed	115 miles per hour	109 miles per hour	101 miles per hour
Gas Mileage	25/27 mpg	26/28 mpg	29/30 mpg
Heater & Defrosters with Electric Blower	Standard	Standard	Standard
Dual Heating System with Rear Window Defroster	Optional	Optional	Optional
Custom Deluxe Equipment	"Pallas" model	"Pallas" model	NA
Custom Leather Interior	Optional on "Pallas"	Optional on "Pallas"	NA
Folding Rear Center Arm rest	Standard	Standard	Standard
Folding Front Center Arm rest	Optional	Optional	Optional
Custom Air Conditioning	Optional	Optional	Optional
Custom AM-FM or AM Radios	Optional	Optional	Optional
Roof Antenna	Optional	Optional	Optional
Reclining Bucket Seats	Standard	Standard	Standard
"Leather-Tex" Upholstery	Optional	Optional	Optional
Dual 2-Speed Electric Wipers	Standard	Standard	Standard
Dual Windshield Washers	Standard	Standard	Standard
Cigarette Lighter	Standard	Standard	Optional
Precision Electric Clock	Standard	Standard	Standard
Models Available	Sedan: 5 passengers, 4 doors Station Wagon: 7/9 passengers (no Citromatic) Convertible	Sedan: 5 passengers, 4 doors Station Wagon: 7/9 passengers (no Citromatic)	Sedan: 5 passengers, 4 doors

Citroen reserves the right to change all Specifications without notice.

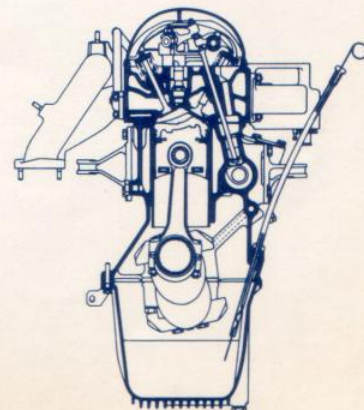
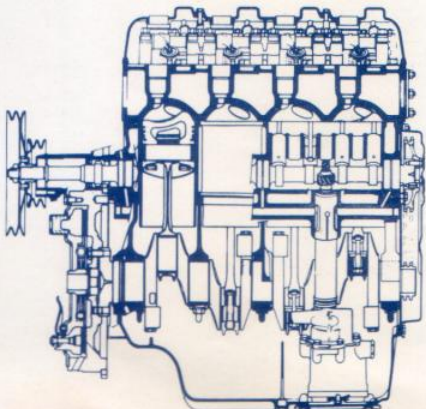



Citroën

**more power... more performance
...new action for '66!**
